

Elephant Eco Bag



Tools

- Spring Tape Measure (Art No. 806)
- Graph Ruler (50 cm) (Art No. 7703)
- Air Erasable Marker, Thick (Art No. 5031)
- Black Gold Needles Applique Sharps No. 9 (Art No. 4970)
- Patchwork Pins (Art No. 232)
- Desk Needle Threader (Art No. 4071/4072/4073)
- Easy Loop Turner (Art No. 472)
- Thread Clipper Kuroha (Art No. 415)
- Rotary Cutter (Art No. 7500)
- Cutting mat (Art No. 4060)
- Bias Tape Cutting Ruler (Art No. 57-924)
- Patchwork Scissors (Art No. 493, 493/L)
- Roll & Press (Art No. 7812)
- Sewing machine
- Press iron

Materials

- 160cm width Calico Fabric, medium weight x 100cm
- Fat Quarters, [A]Green and [B]Yellow-Green with floral pattern
- Sewing thread in matching colours
- Small amount of 3-ply Light-Brown yarn
- Light weight cardboard or sturdy card
- Black beads, 4mm x 2, 2mm x 1

Designed by Sachiyo Ishii

Steps:

1. Cut Calico fabric to the measurement in diagram, using Rotary Cutter.
2. Cut cardboard to elephant and ear templates, using dotted lines.
3. Mark elephant templates on fabric, using Air Erasable Marker.
Cut fabric (templates include 1cm seam allowance).
Use fabric B for smallest and largest elephant body, fabric A for medium elephant body.
Cut slits at sharp bends and work running stitch within seam allowance.
Place cardboard templates at centre of fabric pieces and pull thread tight to gather. Press with iron.



Elephant Eco Bag

4. Mark and cut ears (templates include 1cm seam allowance).
Use fabric A for smallest and largest elephant ears, fabric B for medium elephant ear.
Work as for Body with running stitch and press iron.

5. Prepare tails. Cut 3-ply brown yarn to approx.40 cm for smallest elephant, 60 cm for medium, 90cm for largest elephant.
Work each tail separately.
Tie the two ends of one strand together.
Fold strand again into three so you have six strands lying parallel.
Hold both ends and twist the yarn tightly until it folds up on itself, insert one end slightly through the other to secure (in the same manner you would twist and secure a skein of yarn) and tie the end with another length of yarn.
Cut the loops of the tied end and trim.
Repeat for remaining two tails.

6. Sew elephant motifs on Calico fabric piece, using a Black Gold Needle.
Work over-cast stitches around elephants.
When you come to tail part, insert tail between motif and Calico and work over-cast stitches, piercing through yarn and fabric.

7. Attach ears to elephant.

positions of elephants:
mark centre of bag and elephant
and match markings.

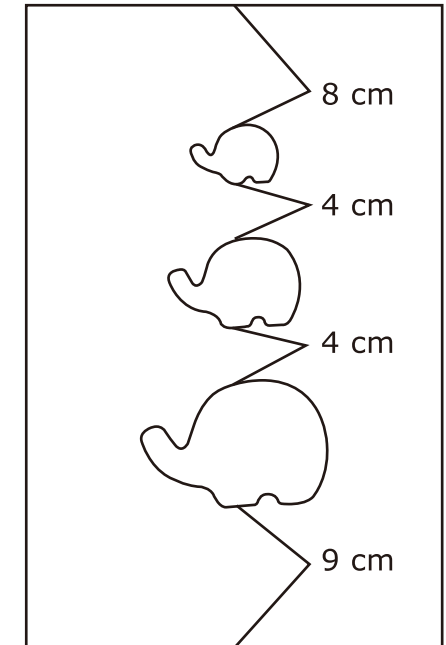

Elephant Eco Bag

8. Using Air Erasable Marker and Plotting Scale, mark sewing lines on Calico fabric pieces, referring to the diagram.

Sew sides with the right sides together.

Open up the allowance with Roll and Press.

Tuck in the allowance and sew over the fold.

Work the bottom edge the same way.

Hand-sew if you cannot machine sew right to the edges over the fold.

This is to give the extra strength and neat finish, however, if you prefer a simple method, work zigzag stitch or lockstitch along edges prior to make up the bag.

9. Fold down top seam allowance 1cm from edge to wrong side.

Fold again at 2cm from first fold, then fold again a further 2cm from previous fold.

Stitch in place along lower edge of fold hem. Sew along top edge.

10. Sew bottom corners, 5cm away from the tip to create gussets (see diagram).

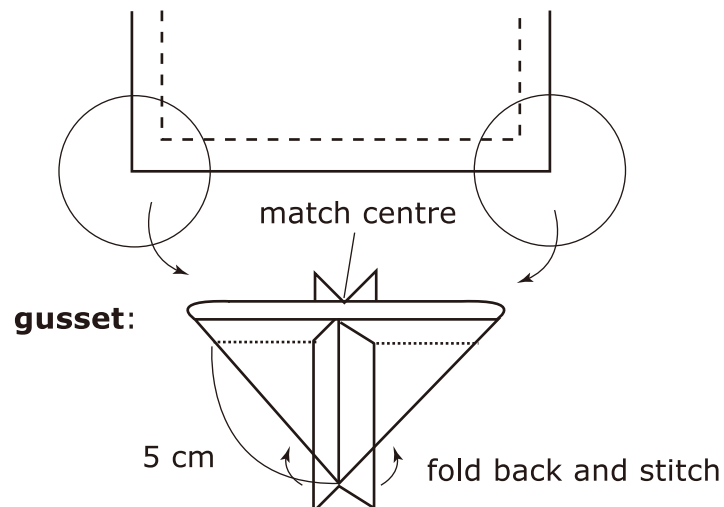
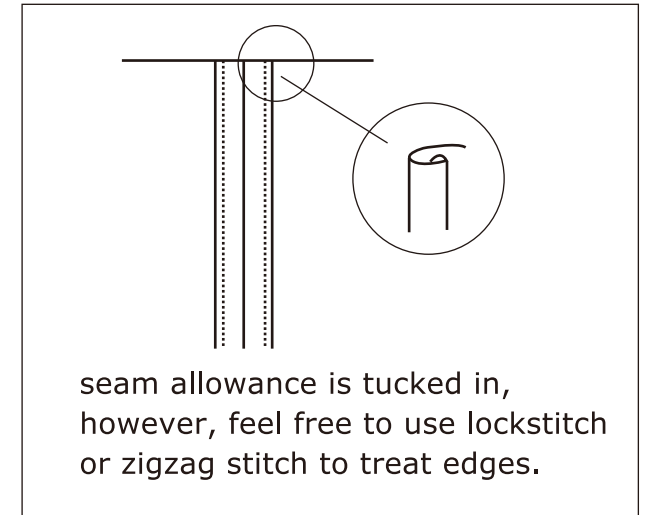

Elephant Eco Bag

11. Cut handles to measurements.
Sew long edge with right sides together.
Turn the piece inside out, using Easy Loop Turner.

12. Fold and tuck in the allowance at the short edges and attach handles to the bag (see diagram).

top edge:

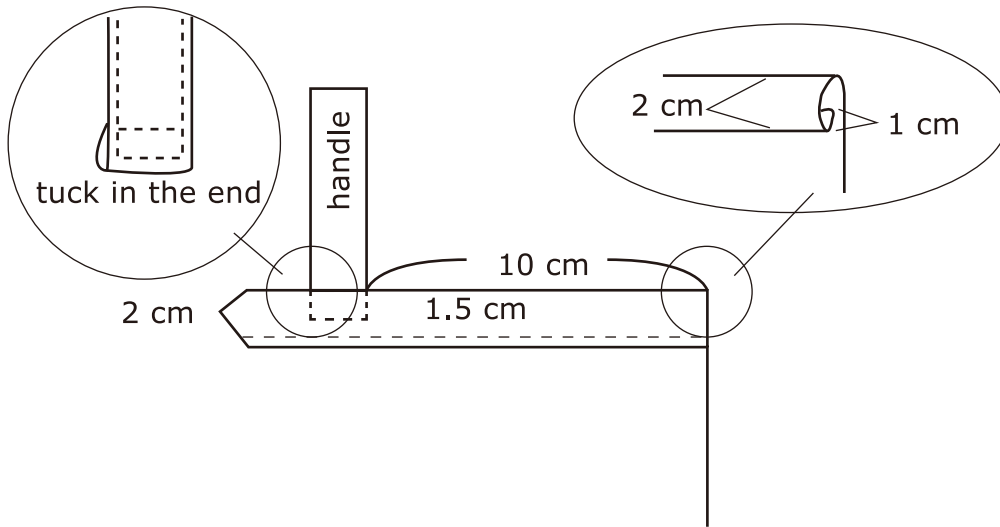

13. Attach eye bead to each elephant.

Elephant Eco Bag

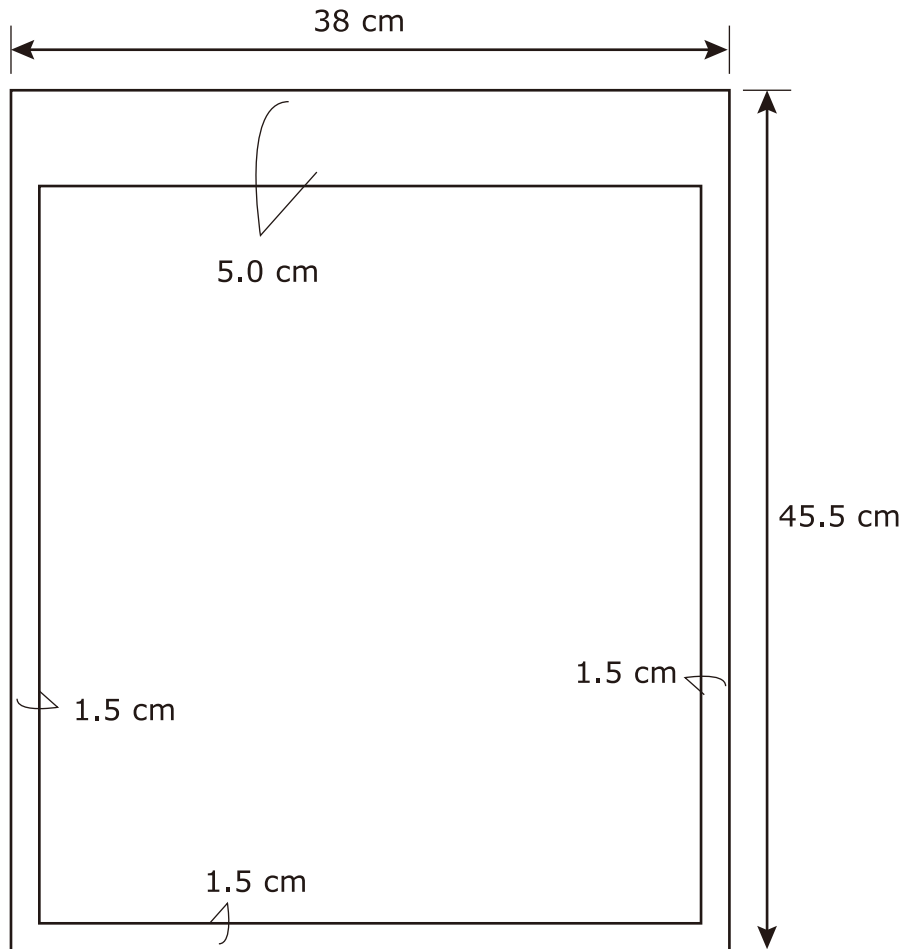
Bag: cut 2

cutting line —————
sewing line - - - - -
measurements are in cm

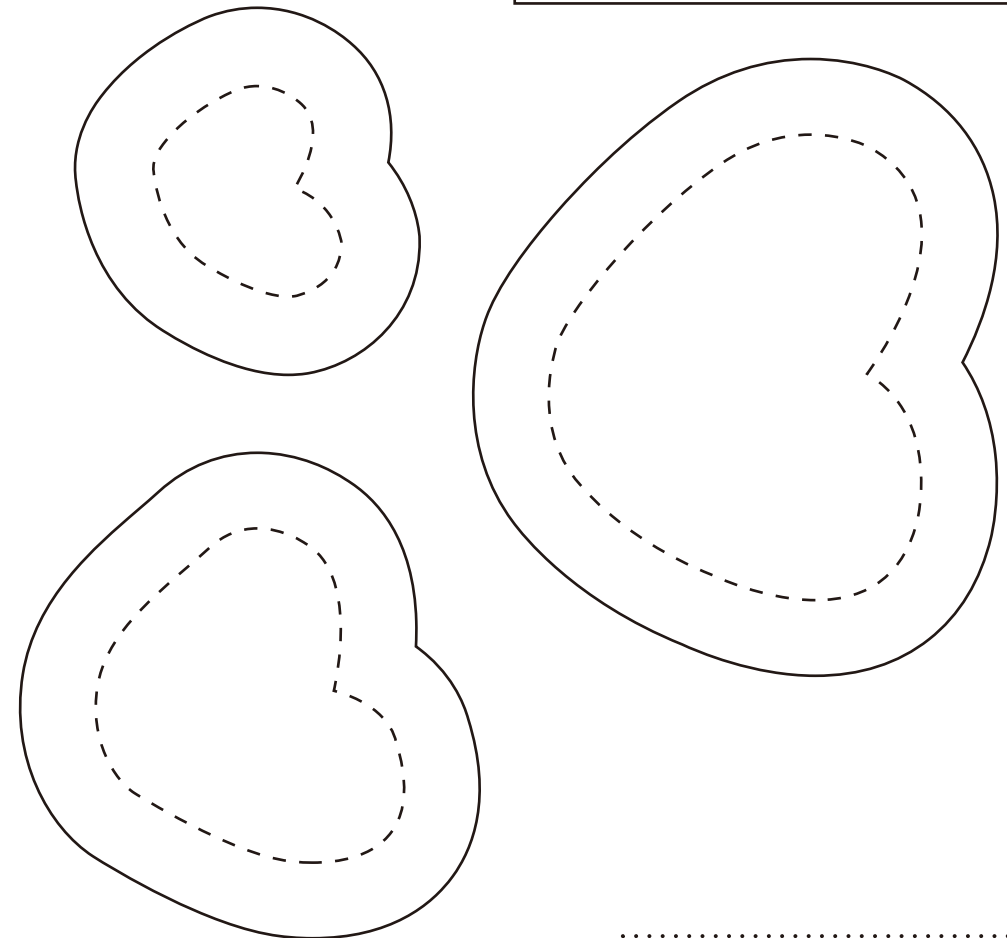
**for handles:**

cut 2

6 x 45 cm rectangle



Elephant Eco Bag

